

INSTYLE DOORS - MEASUREMENT GUIDE

This **STEP BY STEP GUIDE** will help you to measure up for your replacement doors and accessories. The easiest way is to measure your existing carcasses and doors. It is straightforward, but if you require assistance, please contact us.

STEP 1

Inspect your carcasses and doors

Your existing carcasses (ie cupboards or units) should be either 15mm or 18mm thick melamine faced chipboard (MFC). The doors should close onto the outside edge of the carcase and not inside the opening (see figure 1) and should fit without unsightly gaps. The doors should be attached using hinges which at one end fit onto a plate on the inside of the carcase, and at the other are recessed into the back of the door in 35mm circular hinge holes.

Figure 1

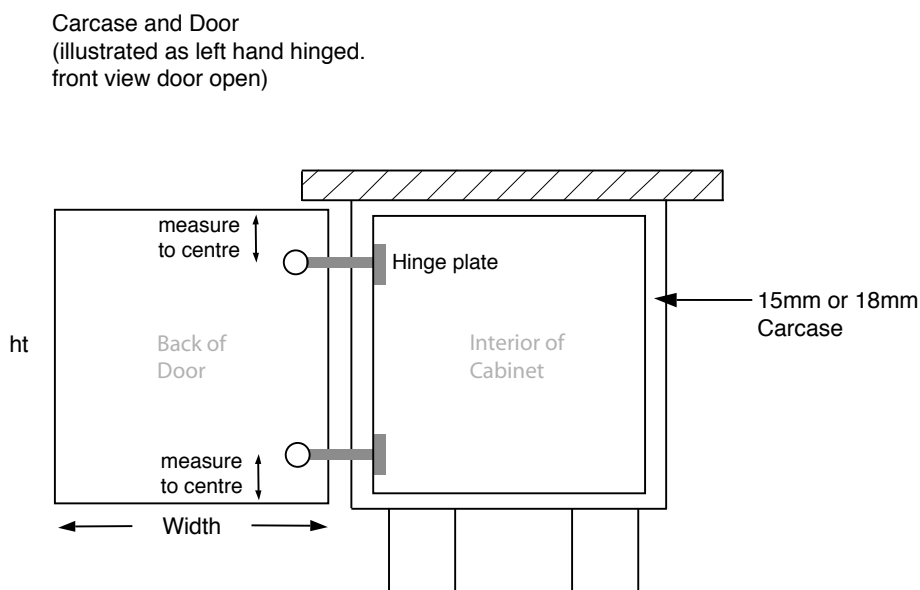

STEP 2

Use the Measurement Checklist and Door and Drawer Measurement Form at the end of this Guide

Note the measurements on these sheets as you go along and use the Checklist to ensure that you have measured the accessories such as plinths and cornices.

STEP 3

Measure the carcasses requiring New Doors

To allow clearance for smooth opening, the overall height of the doors should be 5mm less than the height of the carcase, and the width of the doors 4mm less than the width of the carcase. (see figure 2)

For example, a carcase measuring 720mm(h) x 500mm(w) would require a door measuring 715mm (h) x 496mm(w). So you would order a 715mm x 496mm door.

Figure 2

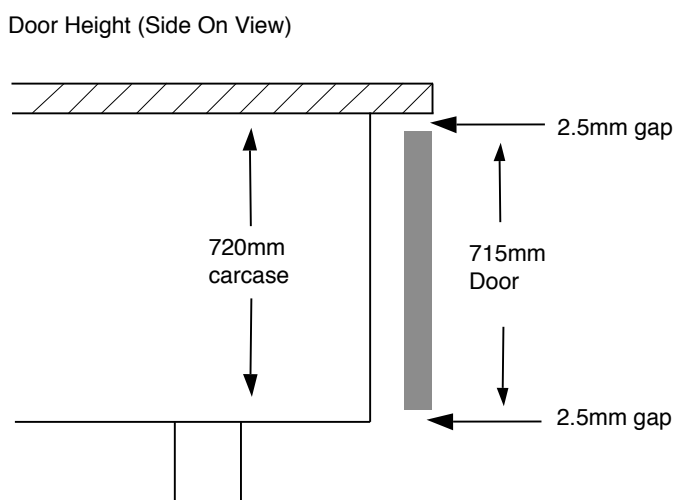

STEP 4

Measure the drawer line carcases

Where a unit has a drawer at the top, again firstly measure the height of the carcase, and then you will need to deduct 5mm from the height of the drawer **AND** 5mm from the height of the door. The width of the drawer and door will again be 4mm less than the width of the carcase.

For example, a carcase measuring 720mm(h) x 500mm(w) would require a drawer measuring 140mm(h) and a door measuring 570mm(h). The drawer and door would each be 496mm wide. So you would order a 140mm x 496mm drawer and a 570mm x 496mm door.

Figure 3

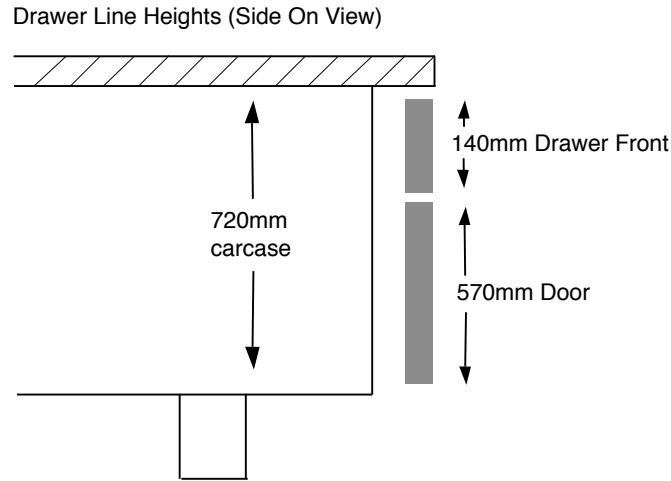

STEP 5

Measure the drawer units

Where a unit has only drawers, again firstly measure the height of the carcase. Then count the number of drawers and divide the overall height by the number of drawers. Subtract 5mm from **each** drawer and you have the height of each drawer. The width of the drawers will again be 4mm less than the width of the carcase.

For example, take a standard 720mm(h) by 500mm(w) base unit, which has 4 drawers.

- The initial measurement per drawer is 720 divided by 4, ie 180mm
- DEDUCT 5mm per drawer, so each drawer is 175mm high
- The width will be 500mm less the usual 4mm, ie 496mm wide

So, in this example, you would order 4 drawers of 175mm x 496mm

Figure 4

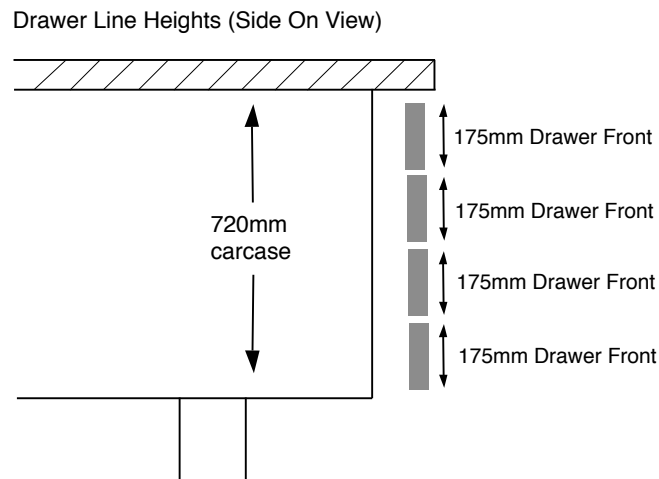

The heights of the standard combinations of drawers and doors are shown in figures 5 and 6.

Figure 5

Standard Drawer and Door Combinations
 Base Unit with 720mm high carcass.
 All heights in mm

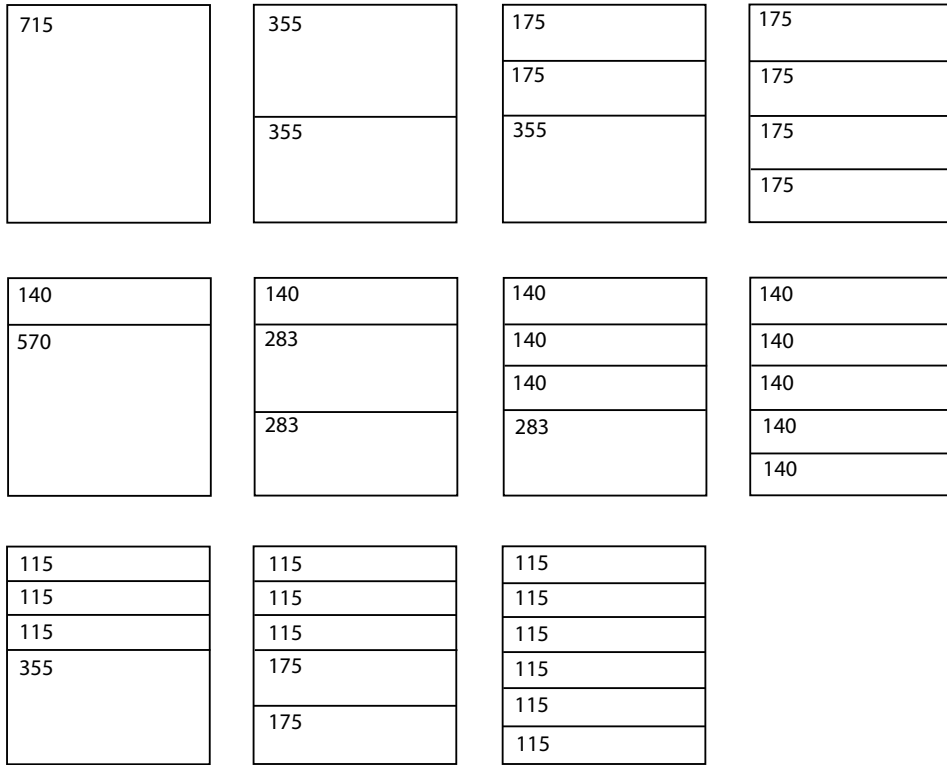
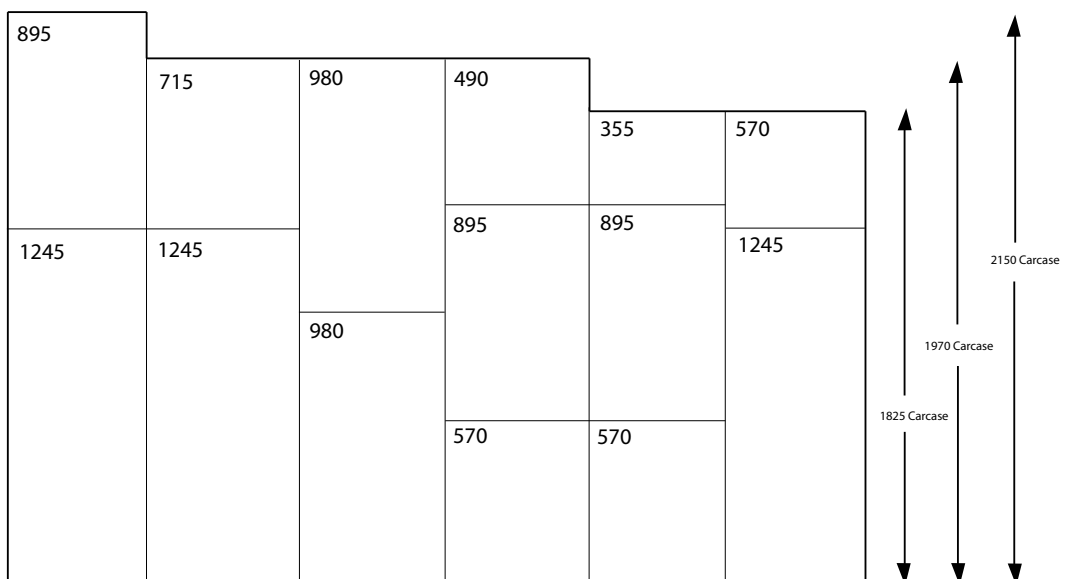

Figure 6

Standard Modular Kitchen Door Combinations



STEP 6

Note the position of the hinges

We offer a service to pre drill 35mm holes in your new doors for the hinges.

If you wish to use your existing hinge positions and hinges, then:

- Measure the height from the top of the door to the centre of the top hinge plate and from the bottom of the door to the centre of the lower hinge plate
- Note whether the door is left or right handed. A door is left-handed if when looking at it in the closed position, the hinges are on the left hand side.
- You do not need to note the handedness of the doors if you are ordering doors which are the same when turned upside down (for instance the Lascari) and if the hinges are the same distance from the top and bottom

Figure 7

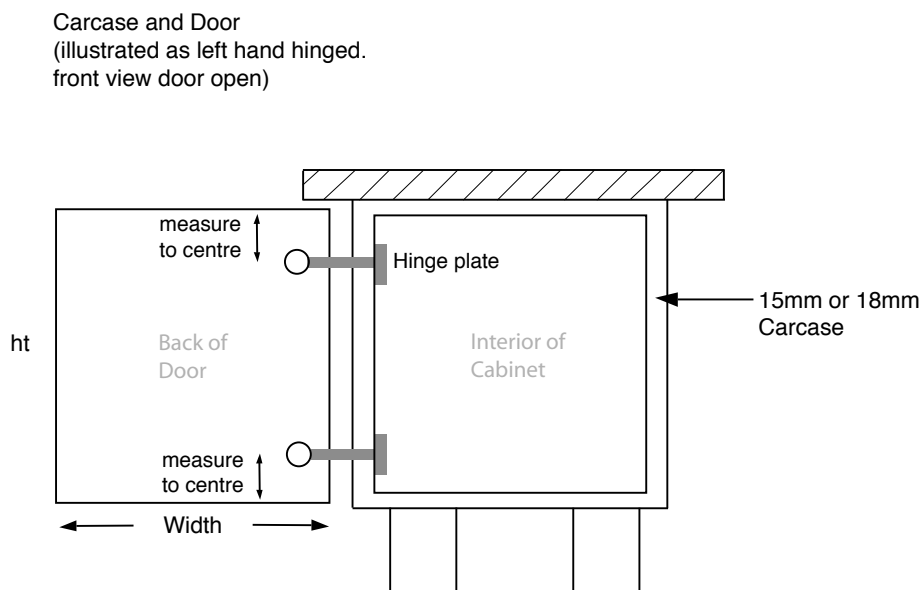

If you wish to use new hinges and plates, then

- We suggest that you select a hinge position 20mm away from the old position, so that the screws for the new hinge plates are away from the old.
- Select positions that are the same from the top and bottom, for instance 80mm, 100mm or 120mm.
- Make sure that the new hinge positions do not interfere with the position of your shelves or internal baskets and wirework.

STEP 7

Measure the Accessories

Measure your existing accessories (such as pelmets and cornices) and note these and new requirements on the Measurement Checklist.

If you require further assistance, please contact us.

INSTYLE DOORS - MEASUREMENT CHECKLIST

PLEASE PRINT OFF AND COMPLETE THIS CHECKLIST to ensure that you have measured and counted all the components you need for your new kitchen. We suggest that you have this Checklist and the Drawer and Door Measurement Form to hand when ordering online from us.

If you require further assistance please contact us.

DRAWERS FRONTS AND DOORS	Measured / counted (√)		
1. Measure the carcasses		TO HELP DETERMINE THE DRAWER AND DOOR SIZES	
2. Base unit doors		PLEASE NOTE YOUR REQUIREMENTS ON THE DRAWER AND DOOR MEASUREMENT FORM	
3. Wall unit doors			
4. Hinge positions and note whether L or R handed			
5. Drawer fronts			
6. End panels			
ACCESSORIES	Measured / counted (√)	Size (mm)	Quantity
1. Plinth			
2. Cornice			
3. Pelmet			
4. Pilaster			
5. Corner posts			
6. Wine rack			
7. Cooker canopy			
8. Base/wall shelf units			
9. Drawer boxes			
10. Handles			
11. Hinges			
12. Vinyl (per sq m)			
13. Edging tape			
14. Plate cot *			
15. Gallery rail *			
16. Post *			
17. Overmantle *			
ADDITIONAL NOTES			













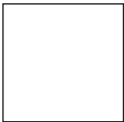









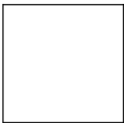

*Solid wood ranges only
2007

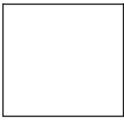
© Instyle Doors Ltd

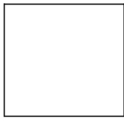
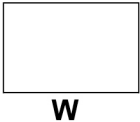
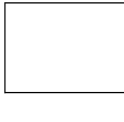
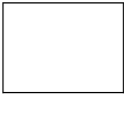
Our full range of accessories (including measurements) is shown at: www.instyledoors.com/accessories

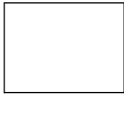
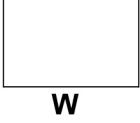
INSTYLE DOORS - DRAWER AND DOOR MEASUREMENT FORM

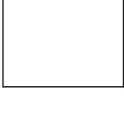
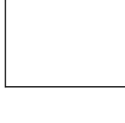
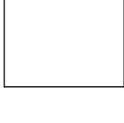
PLEASE PRINT OFF AND COMPLETE by adding height, width measurements and the hinge positions on doors, noting left or right hand.

					Total
BASE UNIT DOORS					
 H W					
 H W				
WALL UNIT DOORS					
 H W					
 H W				
DRAWER FRONTS					
 H W					
 H W				
END PANELS					
 H W	